

**Gebbruiksaanwijzing
Benutzerhandbuch
Manuel d'utilisation
User Manual**

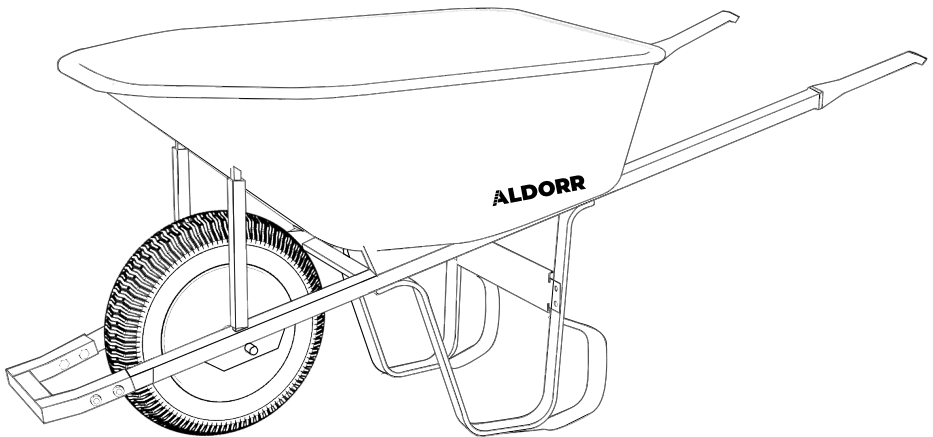

170L

Contents

Dutch	3
German	9
French	15
English	21





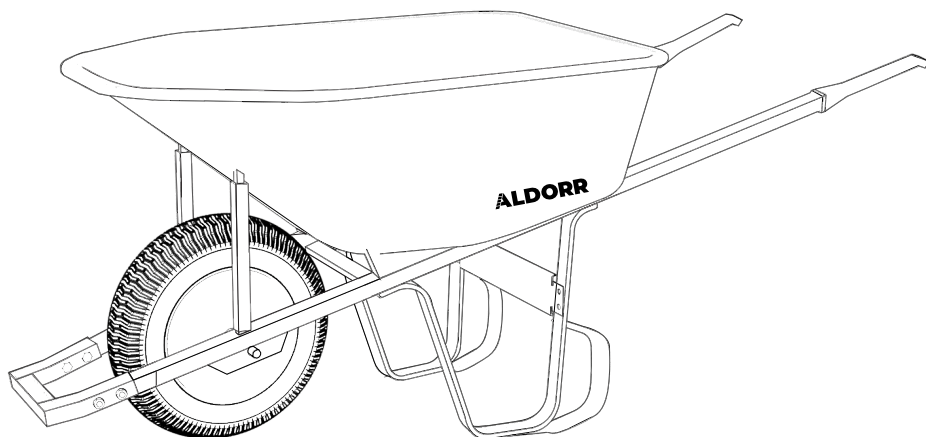

NL

Gebruiksaanwijzing **170L Kruiwagen**

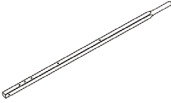
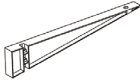
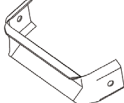

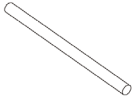
ALDORR

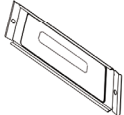
Verpakkingsinhoud

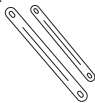
<p>A Handvat x2</p> 	<p>B Tussenstuk x2</p> 	<p>C Wielbeschermer x1</p> 	<p>D Bak x1</p> 	<p>E Assteun x2</p> 	
<p>F As x1</p> 	<p>G Wiel x1</p> 	<p>H Steunbalk x1</p> 	<p>I Baksteun x2</p> 	<p>J Poot x2</p> 	<p>Z Dwarslat x2</p> 

Bevestigingsmateriaal

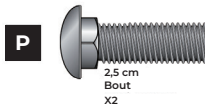
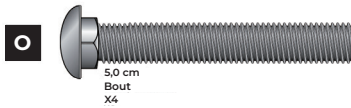
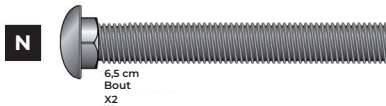
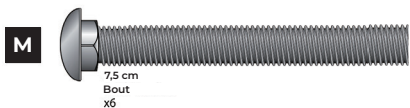
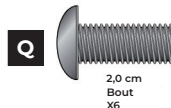
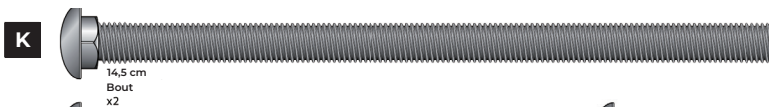

Video uitleg

Overzichtswaergave

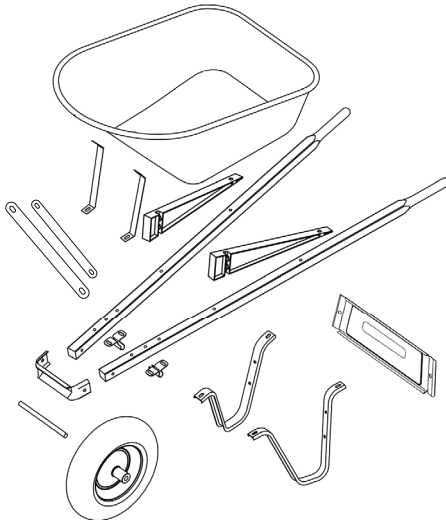

Lees alle instructies door voordat u met de montage begint.

Benodigd gereedschap:

1/2 inch moersleutel of 1/2 inch dopsleutel
Kruiskopschroevendraaier en platte schroevendraaier
Tape

Instructies

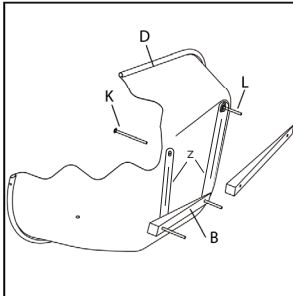

1

Scan AUB de QR code op de vorige pagina voor een eenvoudige montage video. Het volgen van de onderstaande stappen kan als complex worden ervaren.

Duw de bouten (K & L) door de onderkant van de bak (D), dwarslat (Z) en het tussenstuk (B). Herhaal dit voor het tweede tussenstuk.

TIP

Stap 1 tot en met 3 zijn eenvoudiger met een extra persoon.

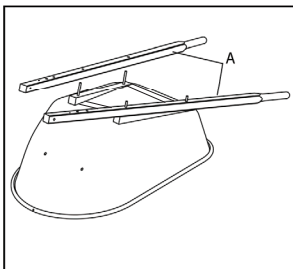

2

Draai de bak om, plaats de handvatten (A) over de bouten en laat ze op de tussenstukken (B) zakken.

3

Zorg ervoor dat de gaten in de poot (J) naar de achterkant van de bak zijn gericht, plaats dan het been over de bouten en bevestig het losjes aan het handvat met moeren (O). Herhaal dit voor de andere poot.

TIP

Draai de moeren op dit moment nog niet vast.

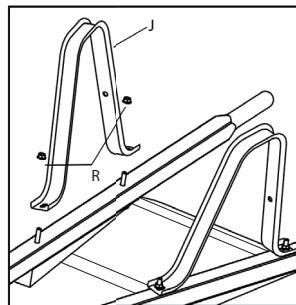
**4**

Plaats de steunbalk (H) over de achterkant van de poot en bevestig losjes met twee bouten (Q) en moeren (R).

TIP

Draai de moeren op dit moment nog niet vast.

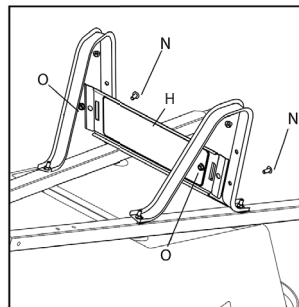
**5**

Gebruik twee Bouten (M) en twee moeren (R) om de wielbescherm (C) aan de voorkant van de handvatten te bevestigen.

TIP

De Bouten moeten naar de binnenkant van de handvatten wijzen. Gebruik een 1/2" moersleutel of dopsleutel om de wielbescherm volledig vast te draaien. Laat de rest van de moeren en bouten losjes vastzitten.

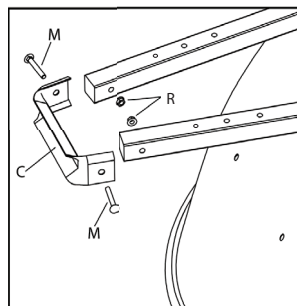

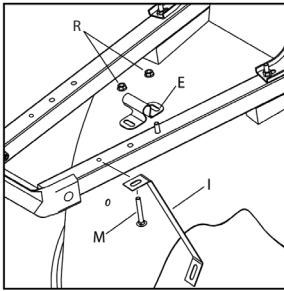

6 Enkel wiel

Bevestig de assteun (E) aan de onderkant van het handvat met een bout (M) die door het gat wordt gestoken dat het dichtst bij de bak zit. Duw de tweede bout (M) door het gat in de onderkant van de baksteun (I), vervolgens door het handvat (gebruik het gat dat het dichtst bij de wielbeschermer zit). Bevestig losjes met moeren (R).

TIP

Draai de moeren op dit moment nog niet vast.

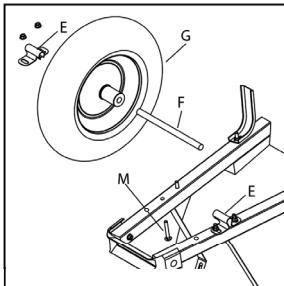

7

Schuif de as (F) door het wiel (G) en vervolgens in de bevestigde beugel. Schuif vervolgens de tweede assteun (E) over het andere uiteinde van de as. Bevestig losjes de tweede assteun en de tweede baksteun aan het handvat. Gebruik Bouten (Q) en moeren (R) om de bovenkant van de baksteunen aan de bak te bevestigen. **Gebruik de meegeleverde dopsleutel i.c.m. met uw boormachine om alle moeren volledig vast te draaien.**

TIP

Om te voorkomen dat het wiel na montage van links naar rechts verschuift, duw de assteunen naar elkaar toe voordat u de moeren vastdraait.

▶▶▶ Zie volgende pagina voor "2 wielen set" ▶▶▶

Extra alleen met "2 wielen set"

S

Platte Ring
X 2

T

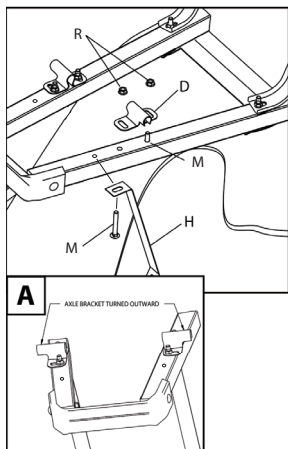
Splijtpen
X 2

6 Dubbel wiel

Bevestig de assteun (D) aan de onderkant van het handvat met een bout (M) door het gat dat het dichtst bij de bak zit. Duw de tweede bout (M) door het gat in de onderkant van de baksteen (H), vervolgens door het handvat (gebruik het gat dat het dichtst bij de wielbeschermer zit) en tenslotte door de assteun. Bevestig losjes met moeren (M). Herhaal om de tweede assteun aan het andere handvat te bevestigen.

TIP

Zorg ervoor dat het lange uiteinde van de assteun naar buiten wijst. Draai de moeren op dit moment nog niet vast.

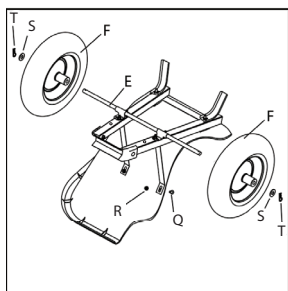

7

Schuif de as (E) door beide assteunen. Monteer het wiel (F) en vervolgens de ring (S) aan het uiteinde van de as. Bevestig door de splijtpen (T) door het gat aan het uiteinde van de as te steken. Herhaal om het tweede wiel te monteren. Gebruik Bouten (Q) en moeren (R) om de bovenkant van de baksteunen aan de bak te bevestigen. **Gebruik de meegeleverde dopsleutel iem met uw boormachine om alle moeren volledig vast te draaien.**

TIP

Zorg ervoor dat elk wiel zo wordt gemonteerd dat het ventiel naar buiten wijst.

DE

Benutzerhandbuch **170L Schubkarre**

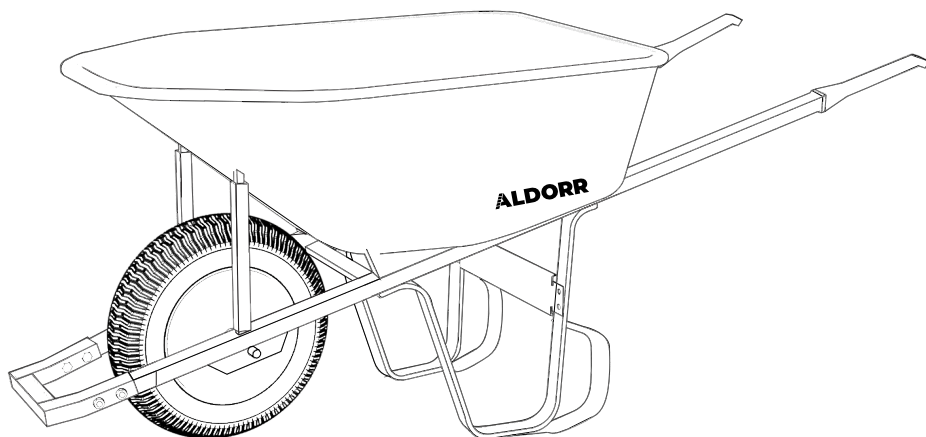









ALDORR

Verpackungsinhalt

A Griff x2	B Verbindungsstück x2	C Radschutz x1	D Wanne x1	E Achshalterung x2
F Achse x1	G Rad x1	H Querstrebe x1	I Wannenstütze x2	J Beine x2
				Z Querstange x2

Enthaltene Befestigungsmaterialien

K	 14,5 cm Bolzen x2	
L	 8,5 cm Bolzen x2	Q
M	 7,5 cm Bolzen x6	 2,0 cm Bolzen x6
N	 6,5 cm Bolzen x2	R
O	 5,0 cm Bolzen x4	 x24 Mutter
P	 2,5 cm Bolzen x2	



Montage- und
Gebrauchsanleitung

DE

Explosionsansicht

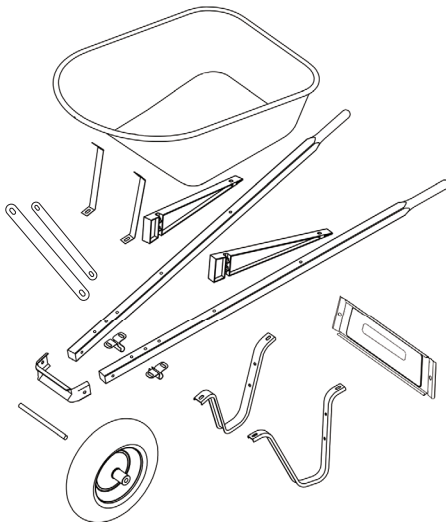

Lesen Sie alle Anweisungen vor der Montage.

Benötigte Werkzeuge:

1/2-Zoll Schraubenschlüssel oder
1/2-Zoll Steckschlüssel
Flacher Schraubendreher

Montageanleitung

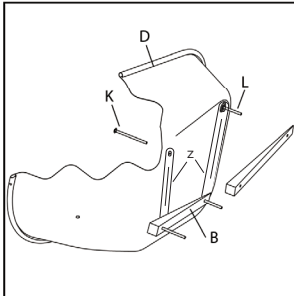

1

Bitte scannen Sie den QR-Code auf der vorherigen Seite, um ein einfaches Installationsvideo zu sehen. Die nachstehenden Schritte können als komplex empfunden werden.

Bolzen (K & L) durch den Boden der Wanne (D), die Querstange (Z) und die Verbindungsstücke (B) stecken.

TIPP

Schritt 1 bis 3 sind einfacher mit einer zweiten Person.

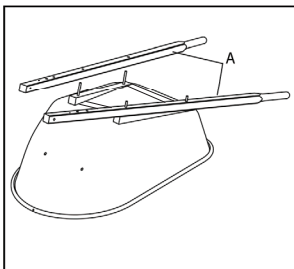

2

Die Wanne umdrehen. Die Griffe (A) über die Bolzen setzen und auf die Verbindungsstücke (B) absenken.

3

Stellen Sie sicher, dass die Löcher in den Beinen (J) zur Rückseite der Wanne zeigen. Setzen Sie dann das Bein über die Bolzen und befestigen es locker mit Muttern (O) am Griff. Wiederholen Sie diesen Vorgang für das andere Bein.

TIPP

Ziehen Sie die Muttern zu diesem Zeitpunkt noch nicht fest.

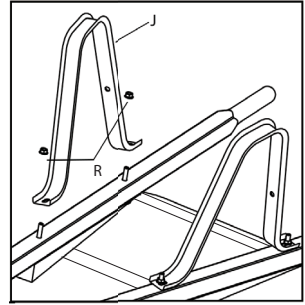
**4**

Platzieren Sie die Querstrebe (H) über die Rückseite des Beins. Befestigen Sie sie locker mit zwei Bolzen (Q) und Muttern (R).

TIPP

Ziehen Sie die Muttern zu diesem Zeitpunkt noch nicht fest.

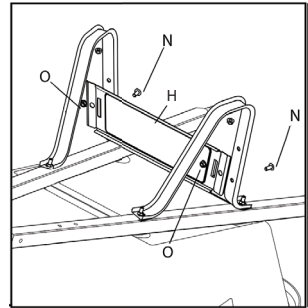
**5**

Verwenden Sie zwei Bolzen (M) und zwei Muttern (R), um den Radschutz (C) an der Vorderseite der Griffe zu befestigen.

TIPP

Die Bolzen sollten zur Innenseite der Griffe zeigen. Verwenden Sie einen 1/2-Zoll-Schraubenschlüssel oder Steckschlüssel, um den Radschutz vollständig festzuziehen. Lassen Sie den Rest der Muttern und Bolzen zunächst locker befestigt.

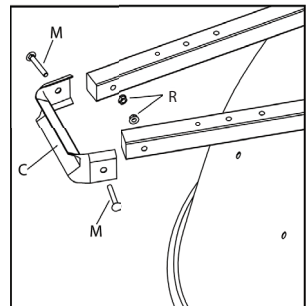

DE

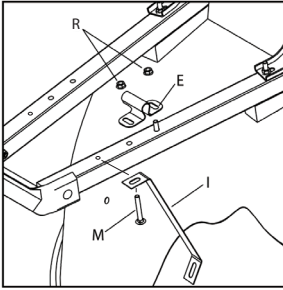

6 Einzelrad

Befestigen Sie die Achshalterung (E) an der Unterseite des Griffs mit einem Bolzen (M), der durch das der Wanne nächstgelegene Loch geschoben wird. Führen Sie den zweiten Bolzen (M) durch das Loch an der Unterseite der Wanneschutz (I), dann durch den Griff (durch das Loch, das dem Radschutz am nächsten ist). Befestigen Sie alles locker mit Muttern (R).

TIPP

Ziehen Sie die Muttern zu diesem Zeitpunkt noch nicht fest.

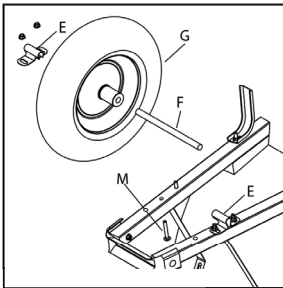

7

Schieben Sie die Achse (F) durch das Rad (G) und dann in die bereits befestigte Halterung. Schieben Sie dann die zweite Achshalterung (E) über das andere Ende der Achse. Befestigen Sie die zweite Achshalterung und die zweite Wanneschutz locker am Griff. Verwenden Sie Bolzen (Q) und Muttern (R), um die oberen Teile der Wanneschutzn an der Wanne zu befestigen. **Benutzen Sie den mitgelieferten Steckschlüssel in Kombination mit Ihrer Bohrmaschine, um alle Muttern vollständig festzuziehen.**

TIPP

Um zu verhindern, dass sich das Rad nach der Montage seitlich verschiebt, drücken Sie die Achshalterungen vor dem Festziehen aneinander.

Zusätzlich nur mit dem "2-Räder-Set" enthalten



Extra nur mit "2-Räder-Set"

S



Flache Unterlegscheibe
X 2

T



Splint
X 2

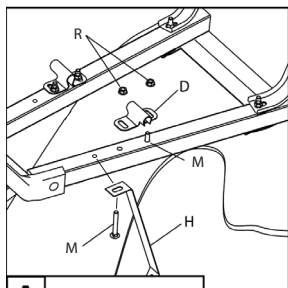

6 Doppelrad

Befestigen Sie die Achshalterung (D) an der Unterseite des Griffs mit einem Bolzen (M), der durch das der Wanne nächstgelegene Loch geschoben wird. Führen Sie den zweiten Bolzen (M) durch das Loch an der Unterseite der Wannenschutz (H), dann durch den Griff (durch das Loch, das dem Radschutz am nächsten ist). Befestigen Sie alles locker mit Muttern (M). Wiederholen Sie den Vorgang für die zweite Achshalterung am anderen Griff.

TIPP

Achten Sie darauf, dass das lange Ende der Achshalterung nach außen zeigt. Ziehen Sie die Muttern noch nicht fest.

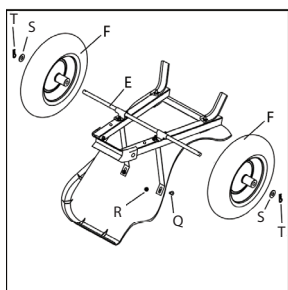
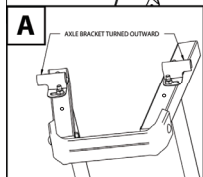

7

Schieben Sie die Achse (E) durch beide Achshalterungen. Setzen Sie die Radbaugruppe (F) und dann die Unterlegscheibe (S) auf das Ende der Achse. Sichern Sie die Montage, indem Sie den Splint (T) durch das Loch am Achsende führen. Wiederholen Sie diesen Vorgang für das zweite Rad. **Benutzen Sie den mitgelieferten Steckschlüssel in Kombination mit Ihrer Bohrmaschine, um alle Muttern vollständig festzuziehen.**

TIPP

Stellen Sie sicher, dass jedes Ventil außen montiert wird.

FR





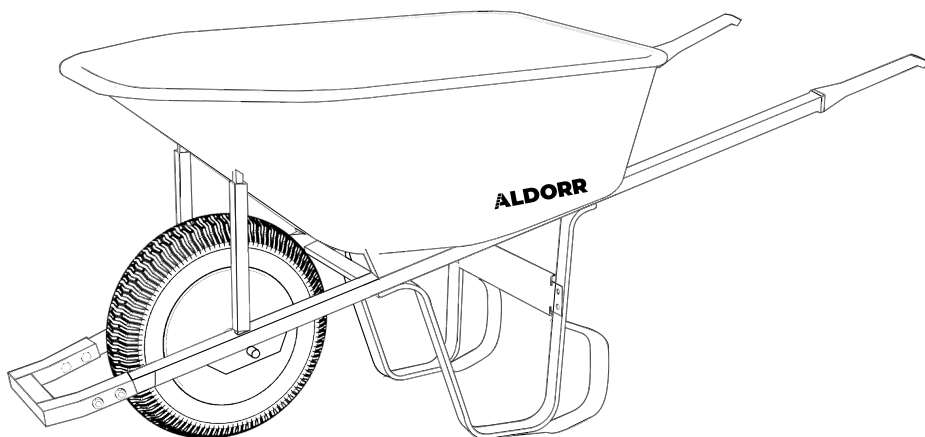

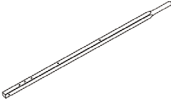
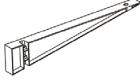
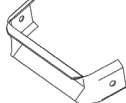

Manuel d'utilisation

Brouette 170L



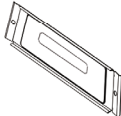



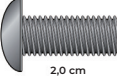

ALDORR

Packaging content

A Poignées x2 	B Rehausseurs x2 	C Garde-roue x1 	D Bac x1 	E Support d'essieu x2 	
F Essieu x1 	G Roue x1 	H Renfort de jambe x1 	I Support de bac x2 	J Pieds x2 	Z Barre transversale x2 

Hardware content

K  14,5 cm Boulon x2	Q  2,0 cm Boulon x6
L  8,5 cm Boulon x2	R  x24 Écrou
M  7,5 cm Boulon x6	
N  6,5 cm Boulon x2	
O  5,0 cm Boulon x4	
P  2,5 cm Boulon x2	



Explication
vidéo

Vue éclatée

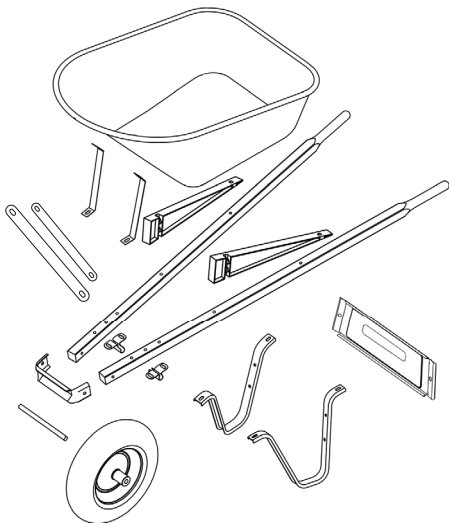

Lisez toutes les instructions avant l'assemblage.

Outils requis :

Clé plate de 1/2 pouce ou clé à douille de 1/2 pouce
Tournevis plat

Instructions

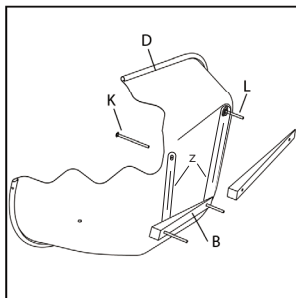
**1**

Veillez scanner le code QR sur la page précédente pour obtenir une vidéo d'installation simple. Les étapes ci-dessous peuvent être considérées comme complexes.

Insérez les boulons (K & L) à travers le bas du bac (D), la barre transversale (Z) et le rehausseur (B). Répétez pour le second rehausseur.

Astuce

Les étapes 1 à 3 sont plus faciles avec l'aide d'une autre personne.

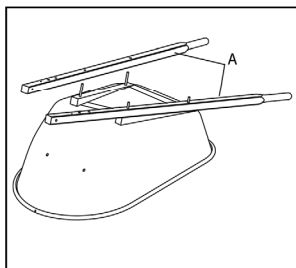
**2**

Retournez le bac, placez les poignées (A) sur les boulons et abaissez-les sur les rehausseurs.

3

Assurez-vous que les trous dans la jambe (J) sont orientés vers l'arrière du bac, puis placez la jambe sur les boulons et fixez-la légèrement à la poignée avec des écrous (O). Répétez pour l'autre jambe.

Astuce

Ne serrez pas les écrous à ce stade.

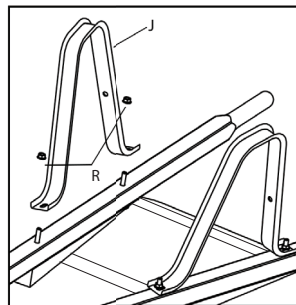

4

Fixez la barre de renfort des jambes (H) à l'arrière des jambes et attachez-la légèrement avec deux boulons (Q) et des écrous (R).

Astuce

Ne serrez pas les écrous à ce stade.

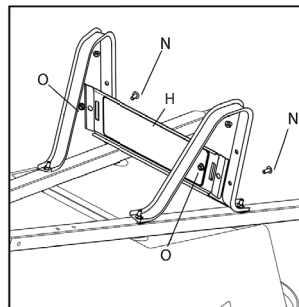

5

Utilisez deux boulons (M) et deux écrous (R) pour fixer le Garde-roue (C) à l'avant des poignées.

Astuce

Les boulons doivent pointer vers l'intérieur des poignées. Utilisez une clé de 1/2 pouce ou une douille pour serrer complètement le Garde-roue. Laissez les autres écrous et boulons légèrement fixés.

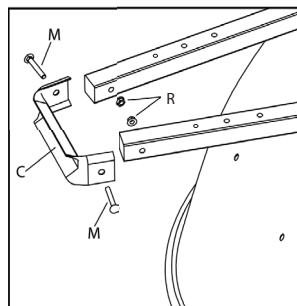

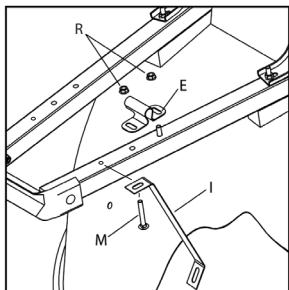

6 Roue unique

Fixez le support d'essieu (E) au bas de la poignée à l'aide d'un boulon (M) inséré dans le trou le plus proche du bac. Insérez ensuite le deuxième boulon (à travers le trou situé en bas du support de bac (I), puis à travers la poignée (en utilisant le trou le plus proche du Garde-roue). Fixez légèrement avec des écrous (R).

Astuce

Ne serrez pas les écrous à ce stade.

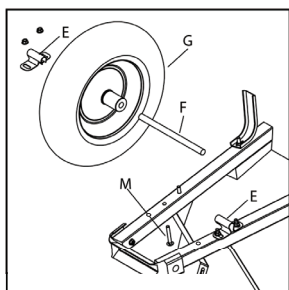

Faites glisser l'essieu (F) à travers la roue (G), puis dans le support fixé. Insérez ensuite le deuxième support d'essieu (E) sur l'autre extrémité de l'essieu. Fixez légèrement le deuxième support d'essieu et le deuxième support de bac à la poignée. Utilisez des boulons (Q) et des écrous (R) pour fixer le haut des supports de bac au bac. **Utilisez la clé à douille incluse avec votre perceuse pour serrer complètement tous les écrous.**

Astuce

Pour éviter que la roue ne glisse latéralement après l'assemblage, poussez les supports d'essieu l'un vers l'autre avant de serrer les écrous.

▶▶▶ Voir la page suivante pour le kit "2 roues" ▶▶▶

Supplément uniquement avec le kit "2 roues"

S

Rondelle plate
X 2

T

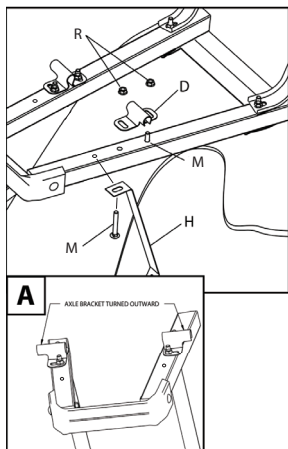
Goupille fendue
X 2

6

Roue double

Fixez le support d'essieu (D) au bas de la poignée à l'aide d'un boulon (M) inséré dans le trou le plus proche du bac. Insérez le deuxième boulon (M) à travers le trou au fond du renfort de bac (H), puis à travers la poignée (en utilisant le trou le plus proche du protège-roue). Fixez légèrement avec des écrous (M). Répétez pour fixer le deuxième support d'essieu à l'autre poignée.

Astuce

Assurez-vous que l'extrémité longue du support d'essieu est orientée vers l'extérieur. Ne serrez pas les écrous pour le moment.

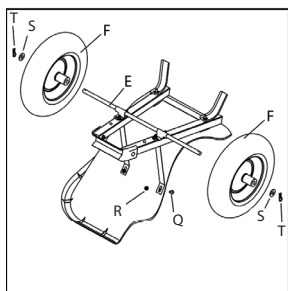

7

Faites glisser l'axe (E) à travers les deux supports d'essieu. Assemblez la roue (g) et ajoutez la rondelle (S) à l'extrémité de l'axe. Sécurisez en insérant la goupille fendue (T) dans le trou à l'extrémité de l'axe. Répétez pour installer la deuxième roue. **Utilisez la clé à douille fournie en combinaison avec votre perceuse pour serrer complètement tous les écrous.**

Astuce

Assurez-vous de monter chaque roue de manière à ce que la valve soit orientée vers l'extérieur.

EN





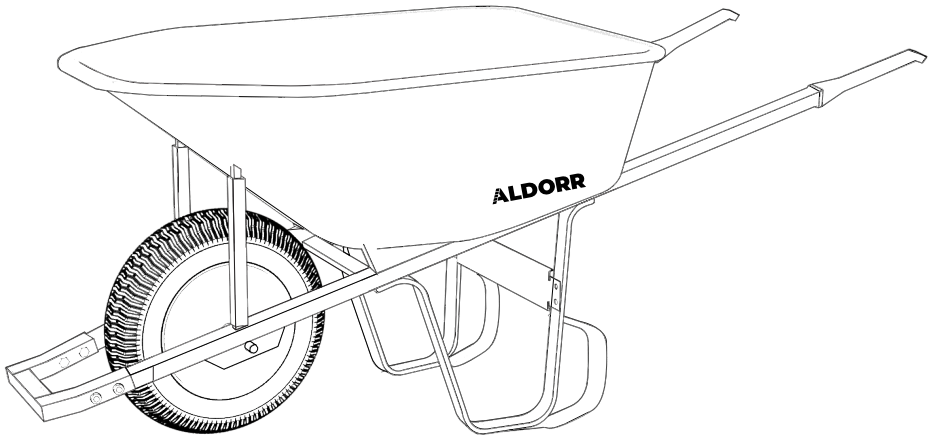

User Manual

6 CUFT Wheelbarrow

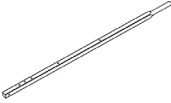
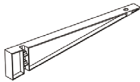
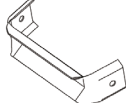



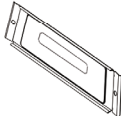

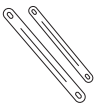





ALDORR

Packaging content

A Handle x2 	B Riser x2 	C Wheel guard x1 	D Tray x1 	E Axle bracket x2 	
F Axle x1 	G Wheel x1 	H Leg brace x1 	I Tray Brace x2 	J Leg x2 	Z Cross bar x2 

Hardware content

K  14,5 cm Bolt x2	L  8,5 cm Bolt x2	Q  2,0 cm Bolt x6
M  7,5 cm Bolt x6	R  X24 Nut	
N  6,5 cm Bolt x2		
O  5,0 cm Bolt x4	Video explanation 	
P  2,5 cm Bolt x2		

Exploded view

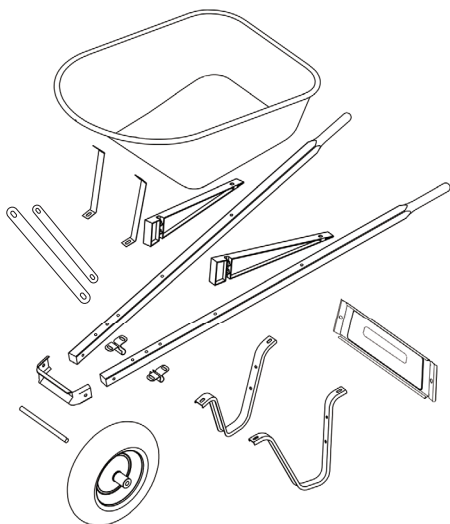

Read all the instructions before assembly.

Tools required:

1/2-inch spanner or 1/2-inch socket spanner
Flat screwdriver

Instructions

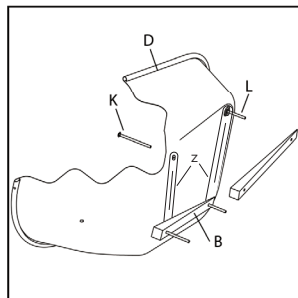
**1**

Scan the QR code on the previous page for a simple installation video. Following the steps below may be perceived as complex.

Push bolts (K & L) through the bottom of tray (D), cross bar (Z) and riser (B). Repeat for the second riser.

TIP

Step 1 till 3 are easier with an extra person's help.

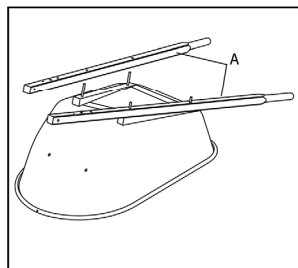
**2**

Turn tray over, place handles (A) over bolts and lower onto risers.

3

Make sure the holes in leg (J) are facing the back of the tray and then place the leg over the bolts and loosely attach to the handle with nuts (O). Repeat for the other leg.

TIP

Don't tighten the nuts at this time.

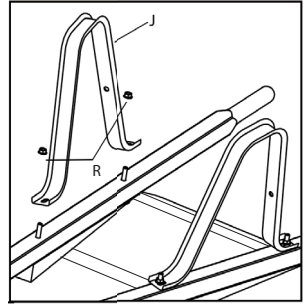
**4**

Place leg brace (H) across the back of the leg and loosely attach using two bolts (Q) and nuts (R).

TIP

Don't tighten the nuts at this time.

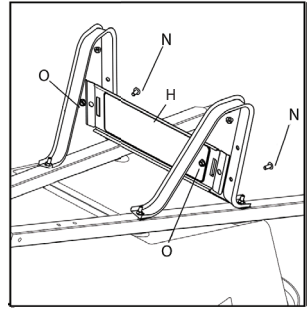
**5**

Use two bolts (M) and two nuts (R) to attach the wheel guard (C) to the front of the handles.

TIP

Bolts should point to the inside of the handles. Use a 1/2" wrench or socket to fully tighten the wheel guard. Leave the rest of the nuts and bolts loosely fastened.

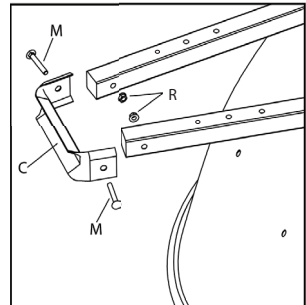

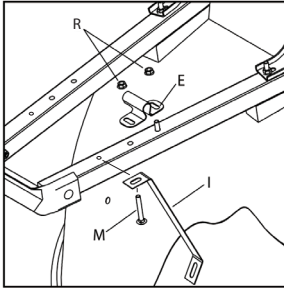

6 Single wheel

Attach axle bracket (E) to the bottom of the handle using a bolt (M) pushed through the hole closest to the tray. Push the second bolt (M) through the hole in the bottom of tray brace (I), then through the handle (using the hole closest to the wheel guard). Attach loosely with nuts (R).

TIP

Don't tighten the nuts at this time.

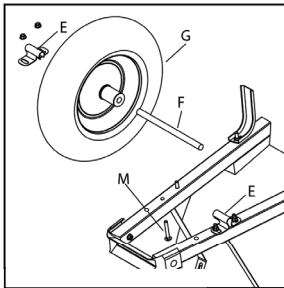

Slide axle (F) through wheel (G) and then into the attached bracket. Then slide the second axle bracket (E) over the other end of the axle. Loosely attach the second axle bracket and second tray brace to the handle. Use bolts (Q) and nuts (R) to attach the tops of the tray braces to the tray. **Use the included socket wrench in combination with your drill to fully tighten all nuts.**

TIP

To keep the wheel from sliding side to side after assembly, push axle brackets toward each other prior to tightening.

See next page for "2 wheels set"

Additional only with "2 wheels set"

S

Flat Washer
X 2

T

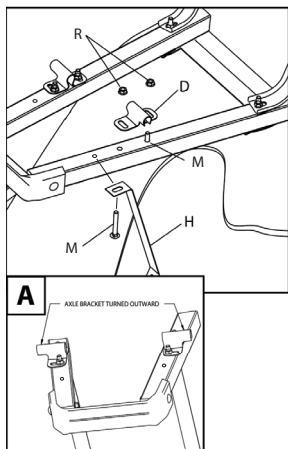
Cotter Pin
X 2

6

Double wheel

Attach axle bracket (D) to the bottom of the handle using a bolt (M) pushed through the hole closest to the tray. Push the second bolt (M) through the hole in the bottom of the tray brace (H), then through the handle (using the hole closest to the wheel guard). Attach loosely with nuts (M). Repeat to attach the second axle bracket to the other handle.

TIP

Be sure the long end of the axle bracket points outward. Don't tighten the nuts at this time.

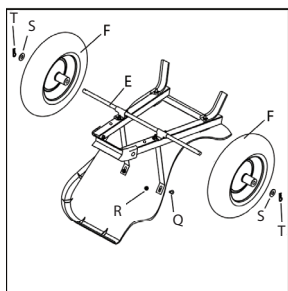

7

Slide axle (E) through both axle brackets. Wheel assembly (F) and then washer (S) onto the end of the axle. Secure by attaching cotter pin (T) through the hole in the end of the axle. Repeat to attach the second wheel. **Use the included socket wrench in combination with your drill to fully tighten all nuts.**

TIP

Be sure to mount each wheel so that the valve stem is on the outside.

ALDORR